

Premolded cable joints, 145 – 170 kV

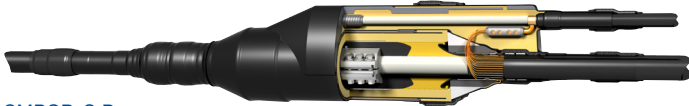

SMPGB



SMPGB-C P



SMPGB-C M

Use

Suitable for jointing XLPE- and EPR-insulated cables with Al- and Cu-conductors. Suitable for jointing two cables having different dimensions or screen/sheath design.

Standard

Meets the requirements of:

- IEC 60840 including Annex H
- IEEE 404, 138 kV

Design

The cable joint consists of a premolded rubber tube and two premolded rubber adapters and a bolt cable clamp. Bolt technology facilitates jointing of the conductor and also allows jointing of different cross sections.

The cable joint SMPGB M for cables with metal-sheath includes also a prefabricated PUR casted copper casing as protective outer jacket.

For diameter over the prepared insulation and conductor diameter, see the table below.

The joint is available in two different types:

- SMPGB Straight cable joint with heat-shrink outer jacket.
- SMPGB-C Cable joint with integrated screen interruption and heat-shrink outer jacket.

The joint is available for different types of cable screens and sheaths.

- C For cables with copper wire screen.
- P For aluminium laminated cables (APL).
- M For cables with metal sheath; lead, corrugated copper/aluminium or corrugated stainless steel.

The following cable data should be stated when ordering, see page 5/1:

- Voltage
- Diameter over prepared insulation
- Conductor cross section
- Conductor material copper or aluminium
- Diameter of conductor
- Screen, sheath design and cross section
- Overall cable diameter
- Optical fibres integrated in screen

Note:

- A torque wrench, installation cone and installation tool RKM 170 are needed for assembling.
- For corrugated copper and stainless steel, the flux is not included in the soldering kit. For flux, please contact your local supplier.

Voltage U_m kV	Cable insulation diameter		Conductor \varnothing mm min/max
	min mm	max	
145	48	107	16–65
170	61	107	16–65

Technical specification

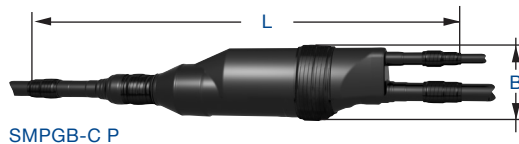
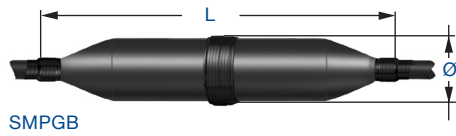

SMPGB

Designation	L mm	Ø
SMPGB 145 C	1300–1950	205
SMPGB 145 P	1600–2250	210
SMPGB 145 M	1620–2220	245
SMPGB 170 C	1300–1950	205
SMPGB 170 P	1600–2250	210
SMPGB 170 M	1620–2220	245

SMPGB-C

Designation	L mm	Ø
SMPGB-C 145 P	1800–2300	410
SMPGB-C 145 M	1800–2300	410
SMPGB-C 170 P	1800–2300	300
SMPGB-C 170 M	1800–2300	340

Selection of cable joint according to cable insulation diameter

Voltage kV	Insulation diameter mm	Conductor diameter* mm	Cable joint size	
			SMPGB C/P/M	SMPGB-C P/M
145	48–51	16–65	SMPGB 14501 C/P/M	SMPGB-C 14501 P/M
145	50–53	16–65	SMPGB 14502 C/P/M	SMPGB-C 14502 P/M
145	52–56	16–65	SMPGB 14503 C/P/M	SMPGB-C 14503 P/M
145	55–59	16–65	SMPGB 14504 C/P/M	SMPGB-C 14504 P/M
145	58–62	16–65	SMPGB 14505 C/P/M	SMPGB-C 14505 P/M
145	61–65	16–65	SMPGB 14506 C/P/M	SMPGB-C 14506 P/M
145	63–68	16–65	SMPGB 14507 C/P/M	SMPGB-C 14507 P/M
145	66–71	16–65	SMPGB 14508 C/P/M	SMPGB-C 14508 P/M
145	69–76	16–65	SMPGB 14509 C/P/M	SMPGB-C 14509 P/M
145	74–82	16–65	SMPGB 14510 C/P/M	SMPGB-C 14510 P/M
145	80–91	16–65	SMPGB 14511 C/P/M	SMPGB-C 14511 P/M
145	89–100	16–65	SMPGB 14512 C/P/M	SMPGB-C 14512 P/M
145	98–107	16–65	SMPGB 14513 C/P/M	SMPGB-C 14513 P/M
170	61–65	16–65	SMPGB 1701 C/P/M	SMPGB-C 1701 P/M
170	63–68	16–65	SMPGB 1702 C/P/M	SMPGB-C 1702 P/M
170	66–71	16–65	SMPGB 1703 C/P/M	SMPGB-C 1703 P/M
170	69–76	16–65	SMPGB 1704 C/P/M	SMPGB-C 1704 P/M
170	74–82	16–65	SMPGB 1705 C/P/M	SMPGB-C 1705 P/M
170	80–91	16–65	SMPGB 1706 C/P/M	SMPGB-C 1706 P/M
170	89–100	16–65	SMPGB 1707 C/P/M	SMPGB-C 1707 P/M
170	98–107	16–65	SMPGB 1708 C/P/M	SMPGB-C 1708 P/M

* Manufactured based on the cable specification.

Tools and accessories

Selection of installation cone according to cable insulation diameter

Voltage kV	Cable Insulation diameter mm	Cable joint size	Installation cone Article number
145	48–51	14501	4209.2384
145	50–53	14502	4209.2385
145	52–56	14503	4209.2386
145	55–59	14504	4209.2387
145	58–62	14505	4209.2388
145	61–65	14506	4209.2331
145	63–68	14507	4209.2332
145	66–71	14508	4209.2333
145	69–76	14509	4209.2334
145	74–82	14510	4209.2335
145	80–91	14511	4209.2336
145	89–100	14512	4209.2337
145	98–107	14513	4209.2400
170	61–65	1701	4209.2331
170	63–68	1702	4209.2332
170	66–71	1703	4209.2333
170	69–76	1704	4209.2334
170	74–82	1705	4209.2335
170	80–91	1706	4209.2336
170	89–100	1707	4209.2337
170	98–107	1708	4209.2338

Tools and accessories, to be ordered separately

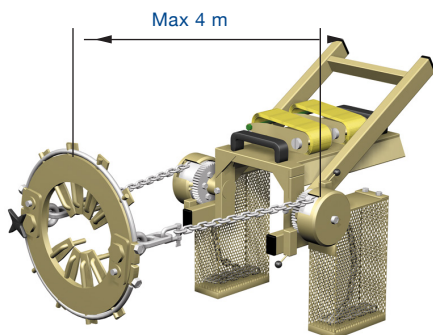

RKM 170
Installation tool for SMPGB joint
145–170 kV.



Installation cone
For installing the adapters.



OKJ 4 and OKJ 5
Opto fiber kit for cables with integrated
optical fibers in the screen.

Opto fiber kits

Cable joint	Suitable opto fiber kit	Article number
SMPGB 145–170 P	OKJ 4	6248.0009
SMPGB-C 145–170 P	OKJ 4	6248.0009
SMPGB 145–170 M	OKJ 5	6248.0010
SMPGB-C 145–170 M	OKJ 5	6248.0010
SMPGB 145–170	OKJ 4	6248.0009

Designation	Description	Weight kg/item
RKM 170	Installation tool	42
Installation cone	Installation cone	~ 0.5