



IPS2

Fault Passage Indicator with Flexible Indications and Settings



IPS2 is a fault passage indicator for overcurrent and directional earth faults that indicates using its relay output. Supplied by internal supercapacitors, it provides local indication using an external LED for 24 hours without external power supply.

Since the algorithm for earth fault detection does not require a voltage transformer and the indications do not need battery backup, IPS2 gives a very cost-efficient fault detection with high sensitivity for pass through faults in impedance earthed networks.



Fault Detection

IPS2 is a fault detector for overcurrent and directional earth faults.

Overcurrent, OC

Pickup level and time delay can be chosen from predefined combinations according to the following table.

Level	Time Delay
$1.3 \times I_p/I_s$	0.5 s
$2.0 \times I_p/I_s$	0.04 s
$2.0 \times I_p/I_s$	0.2 s
$2.5 \times I_p/I_s$	0.04 s
$2.5 \times I_p/I_s$	0.2 s
$3.0 \times I_p/I_s$	0.04 s
$3.0 \times I_p/I_s$	0.2 s

I_p/I_s is the current transformer ratio.

Earth Fault, EF

Ensto Protrol's patented *Fault Pass Through* earth fault detection method for impedance earthed or isolated networks. Capable of detecting high impedance and arcing earth faults. Note that no voltage measurement is necessary for good selectivity at very low currents. The sensitivity is comparable with that of a directional earth fault protective relay.

Pickup level and time delay can be chosen in the following combinations.

Level ¹	Time Delay
1.0 A	-
1.0 A	0.2 s
1.5 A	-
1.5 A	0.2 s
2.0 A	-
2.0 A	0.2 s
10.0 A	0.2 s

¹ The level reflects primary fault current and corresponds to the base ratio 300/1. If current transformers with ratio 150/1 are used, the setting range is 0.5 – 5.0 A.

Functional Overview

A typical detection sequence during a fault is illustrated in the figure below. A fault after the IPS2 unit trips the main protection for the feeder.

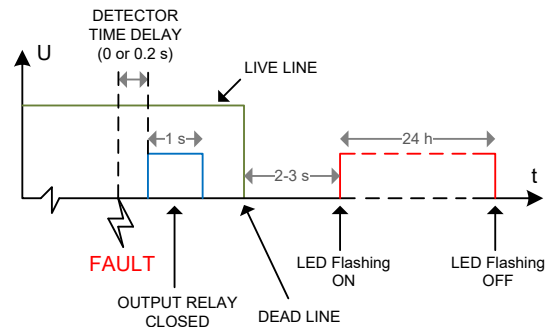

Other Functions

HMI – User Interface

Detected overcurrent or earth fault is indicated by diodes on the front panel. They will reset automatically after 24 hours.

Separate diodes indicate status for power supply and internal supervision.

Transient Fault Recorder

A built-in transient fault recording function registers currents and events from the last detected fault. It is possible to connect to the internal RS232-port to analyze signals and events.

Options

The external LED unit of the standard IPS2 model starts to indicate that the fault current has passed only when the line is dead, thus disconnected upstream, while the relay output is activated immediately. Simultaneous immediate activation can be specified as an option.



Technical Data

General

Dimensions²: 129 × 198(230) × 68 mm.

Mounting: Two holes for plate/wall

Ambient temp: -40 – +70 °C

Supply voltage: 230 VAC

Supply current: appr 5 mA at 230 VAC

Standards: EN 61000-6-2 – Immunity
EN 61000-6-4 – Emission class B
EN 61000-6-5 – For installation in
medium voltage substations
EN 60068-2 – Environmental

Tests according to: EN 61000-4-2
EN 61000-4-3
EN 61000-4-4
EN 61000-4-6
EN 60068-2-1
EN 60068-2-2
EN 60068-2-30

EU directives: ROHS, EMC, LVD

² Height 230 mm includes the cable protection of the contacts (included).

Internal Port:

RS232: 19 200 Bps

Inputs and Outputs:

LED output: Yes, connects to external LED unit

Binary outputs: 1 power relay, 8 A breaking
current at 30 VDC

Analogue inputs: Phase currents, 1 A

Ordering Information

Article Number

The article number is specified as PT101122 (-XYZ).

Basic version: PT101122

Options

IPS2 can also be ordered with additional functionality which is specified by the following postfix to the article number of the basic version.

Option X = Hardware version 0-9

0 – Basic version

1 – High ratio³

Option Y = Communication protocol 0-9

0 – Basic version, no protocol

Option Z = Software options 0-9

0 – Basic version

1 – LED indication does not wait
for dead line before activation

³ Higher internal ratio, 3 x, increases dynamics but reduces accuracy by the same grade.

Example article number

IPS2 with LED indication without dead line req.: 101122-001.

Optional Parts

External LED unit: PT606540



Schematic Overview

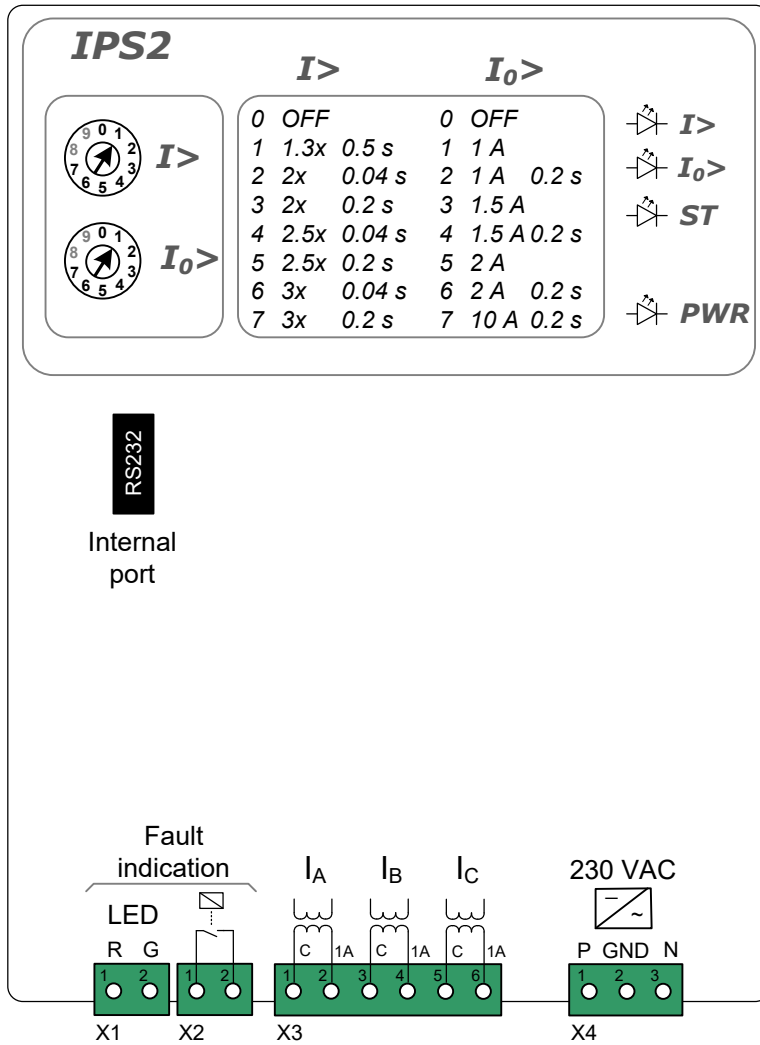



Typical Application

This is the most basic solution with only local indication. The secondary stations are supplied with fault detectors of type IPS Light or IPS2 with visual indication (flashing LED; red or green).

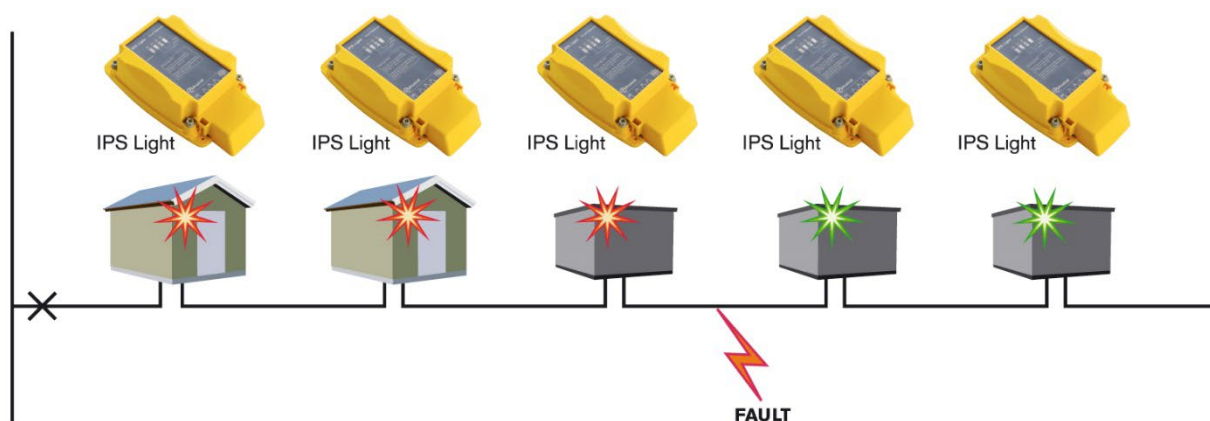

The stations “upstream the fault” are flashing red, while those “downstream the fault” are flashing green. The repair personnel can thereby easily and fast localize the fault on the cable.

In strategic stations with circuit breakers, IPS2 can disconnect faults automatically. The detector then operates as a protective relay. Note that with a pre-charged spring no auxiliary power is needed in the station, the trip coil can be powered by the secondary voltage of the transformer.

